

#### Technical Data

Light fitting for indoor use only

Power Factor: 1

Bulb to be used:

2 x E26 TYPE A19 60W 

2 x E26 CFL TYPE T 13W 

2 x E26 LED TYPE A 11W 

It is recommended that a professional electrician be responsible for installing the light.

**Warning:** If the wire or flexible cord is damaged, it must only be changed by the manufacturer, their Service Dept. or qualified personnel in order to avoid risk.

#### Cleaning Instructions

Use a soft damp cloth, with soap or neutral detergent. Do not use alcohol or other solvents.

#### Datos Técnicos

Luminaria para uso interior

Factor de Potencia: 1

Lámpara a utilizar:

2 x E26 TYPE A19 60W 

2 x E26 CFL TYPE T 13W 

2 x E26 LED TYPE A 11W 

*Se recomienda que la instalación sea realizada por un profesional.*

**Aviso:** Si el cable flexible o cordón de esta luminaria está dañado, deberá sustituirse exclusivamente por el fabricante o su servicio técnico o una persona de cualificación equivalente con objeto de evitar cualquier riesgo.

#### Instrucciones para la limpieza

*Utilizar un paño suave, humedecido con agua y detergente neutro si fuera necesario. No utilizar alcohol o otros disolventes.*

#### Dry location only



This symbol on the product or its packaging indicates that it must not be treated as household waste. It should, in fact, be handed in at a recognised collection point for recycling electrical and electronic equipment. For more detailed information about the recycling of this product, please contact your local city office, your household waste disposal service or the shop where you purchased the product.

*Este símbolo en su equipo o embalaje indica que el presente producto no puede ser tratado como residuo doméstico normal, sino que debe entregarse en el correspondiente punto de recogida de equipos eléctricos y electrónicos. Para recibir información detallada sobre el reciclaje de este producto, por favor, contacte con su ayuntamiento, su punto de recogida más cercano o el distribuidor donde adquirió el producto.*

120 V - 60 Hz

**marset** 

# MARANGA C

Assembly Instructions / Instrucciones de Montaje

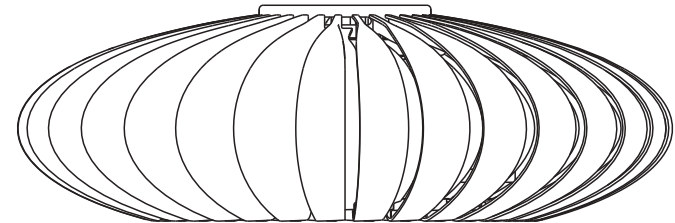

**marset**

1.1

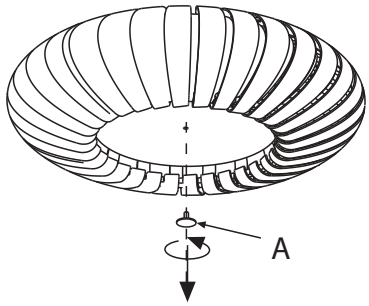

1.2

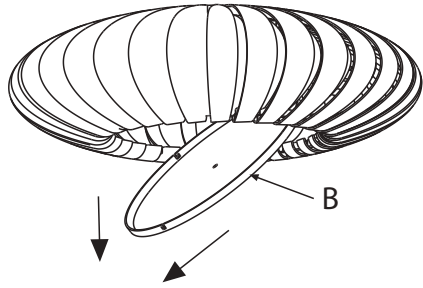

2.

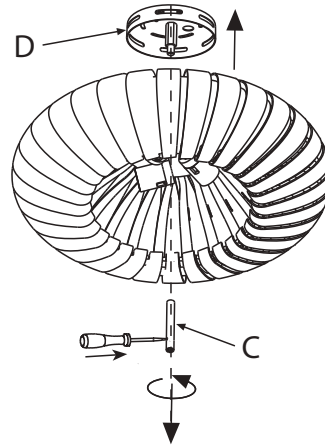

3.

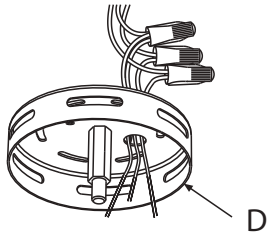

4.

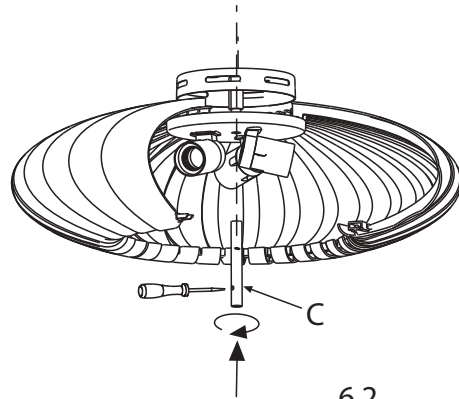

5.

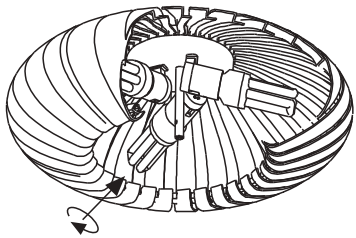

6.1

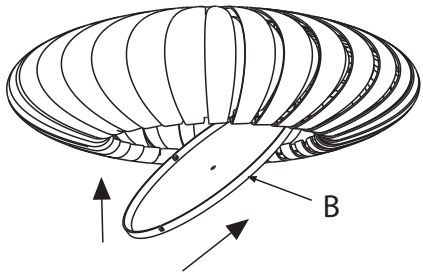

6.2

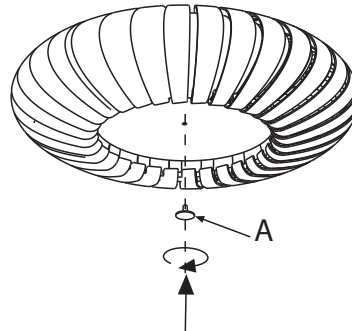
**IMPORTANT SAFETY INSTRUCTIONS:**

1. Read all instructions completely before beginning installation. Keep these instructions in a safe place for future reference.
2. To reduce risk of fire and over-heating, make sure all connections are tight.
3. Connect this product only to a 120V 60 Hz electrical supply.
4. Before installing, disconnect energy.

**Warning!**

Disconnect power supply before installation and change the bulb only when cold.

**Atención!**

Desconectar la conexión a red antes de ser manipulada y realizar el cambio de bombilla sólo cuando ésta se haya enfriado.

1. Remove the screw (A) and the diffuser (B) as fig. 1.1 and fig.1.2 show.
2. Unscrew the metal tube (C) with the help of a screwdriver to separate the canopy (D) from the luminaire.
3. Make electrical connections into the outlet box. Fix the canopy (D) to the outlet box.
4. Re-attach the luminaire to the canopy tightening the metal tube (C).
5. Insert the recommended bulbs.
6. Insert the diffuser (B) and fix it with the screw (A) as Fig.6.1 and 6.2 show.

1. Quitar el tornillo (A) y sacar el difusor (B) tal y cómo se ve en las figuras 1.1 y 1.2.
2. Desenroscar el tubo metálico (C) con la ayuda de un destornillador y separar el florón (D).
3. Hacer las conexiones eléctricas dentro de la caja de conexiones. Fijar el florón (D) a la caja de conexiones.
4. Fijar la luminaria al florón de nuevo apretando el tubo (C).
5. Colocar las bombillas recomendadas.
6. Colocar de nuevo el difusor (B) y fijarlo con el tornillo (A) tal y cómo muestran las figuras 6.1 y 6.2.